

# **Practical Aspects of Electrical Protection**

Jim Wilks Dip EE, Grad Dip MS  
**Manager**

**DATASHARE POWER ENGINEERING SOFTWARE**

**PO Box 772  
Mona Vale NSW  
Australia 1660**

Phone: +61 2 9979 7240  
Fax: +61 2 9997 1339

Revision: 1

e-mail: [jwilks@datashare.com.au](mailto:jwilks@datashare.com.au)  
<http://www.datashare.com.au>

## Introduction

This paper looks briefly at some of the practical issues mine electrical engineering staff are faced with in their day-to-day work involving electrical protection and that may impinge on their performance and the discharge of their responsibilities – both legal and professional.

The practical issues selected for consideration include.

- ❑ Protection coordination
- ❑ Sources of network data – sources of acceptable substitute values
- ❑ Protection philosophies and protection coordination under contingency operating conditions
- ❑ Protection records maintenance

---

## Protection Coordination

### Basic Protection Coordination Objectives

Basic objectives of the protection coordination process are to design protection systems and determine protection system settings that will:

- ❑ Reliably & selectively detect faults & initiate prompt disconnection/isolation. Promptness implies operating quickly enough to avoid, or acceptably limit, any risk to personnel or the public, damage to plant and equipment, or the stable operation of the network.
- ❑ Disconnect only the smallest part of the network necessary to isolate the fault
- ❑ Operate only for prescribed fault conditions (eg. will operate stably for through-faults)
- ❑ Provide backup - in event of failure of a primary device then a backup device should clear the fault still within an acceptable, though longer, time.
- ❑ Aid fault diagnosis & location

Every part of the network must be included within the protection zone one or more protection devices.

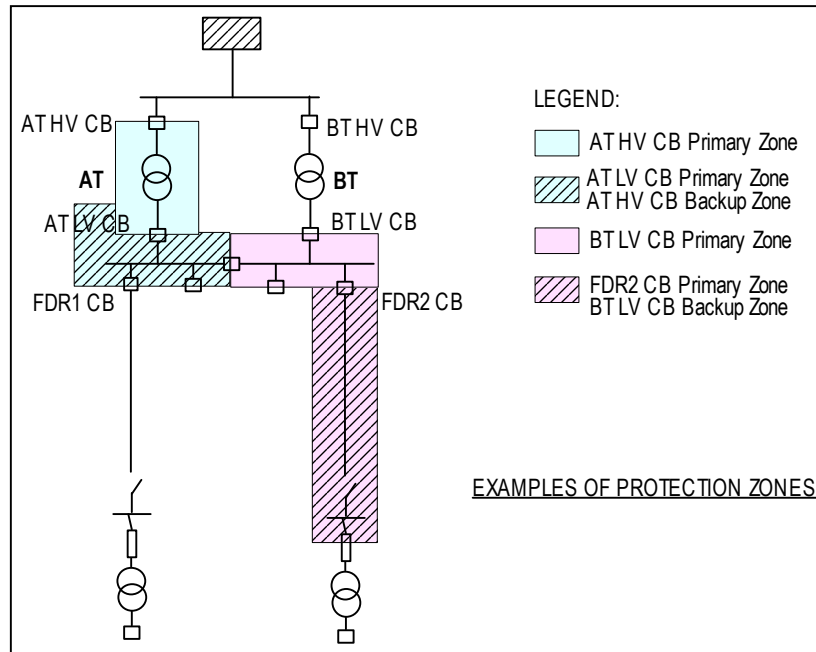

Figure 1: Examples of “Protection Zones”

## Protection Discrimination

Protection coordination<sup>1</sup> may be achieved by utilising one, or a combination, of:

- ❑ Current discrimination
- ❑ Time discrimination

A combination of current and time discrimination is employed in the coordination of Inverse Definite-minimum Time (IDMT) protection devices, typically used in the mining industry.

## CURRENT DISCRIMINATION

Current discrimination can be used when there is sufficient difference between the maximum possible operating currents for the primary and backup devices of a pair of devices that need to be coordinated.

For example, the setting of instantaneous elements in over-current relays is generally based on current discrimination.

## TIME DISCRIMINATION

Time discrimination requires time settings to be selected that will ensure a primary protection device will clear a fault in its protection zone as quickly as possible and that any backup devices will not operate – taking into account relay overshoot<sup>2</sup> – if the primary device successfully clears the fault by normal operation.

<sup>1</sup> Also referred to as “Protection Grading”

<sup>2</sup> Relay overshoot – also known as over-travel or coasting time – refers to the tendency for a relay to continue to operate for some time after the operating current is reduced to zero (eg. when the fault is cleared). In electro-mechanical relays this may be around 0.15 sec due to the inertia of the rotating parts, while overshoot for numerical relays is comparatively quite low, at around 0.02 sec.

## Discrimination Times

### NEED FOR A DISCRIMINATION TIME MARGIN

A discrimination time margin is needed to ensure selectivity (i.e. limiting the outage to the smallest part of the network necessary to isolate the fault) to limit the potential for overlap of the operation of primary and backup devices due to

- Total clearing time of the primary circuit breaker
- Relay overshoot of the backup device
- Any uncertainties about operating times, errors in network data/calculated fault currents, C.T. errors, etc.

This is illustrated in Figure 2 below.

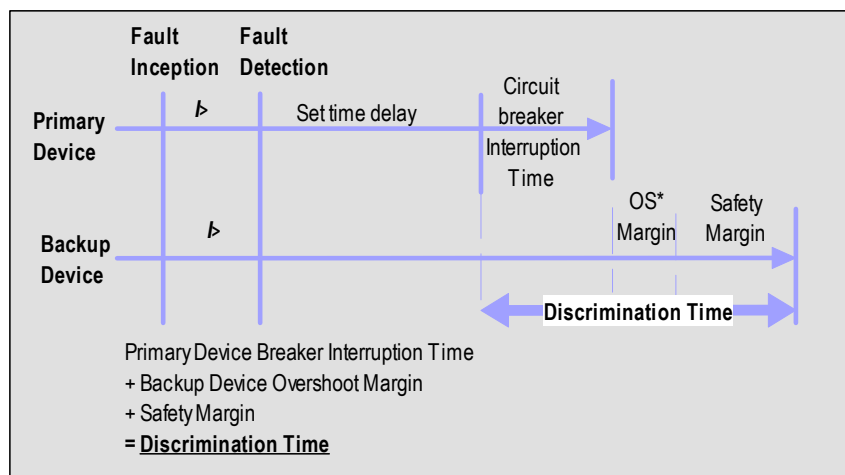

*Figure 2:* Illustration of the Discrimination Time concept.

### HOW MUCH IS ENOUGH? ... OR, HOW LOW CAN YOU GO?

In the era of electro-mechanical relays and bulk-oil circuit breakers, the conventional wisdom was to go for an 0.4 second discrimination time, if you could get it, but be prepared to trim this a little where it was impossible to get. Later standards recommended were 0.3 seconds where fast operating (4-5 cycles) circuit breakers were involved.

As to how far you could trim, Warrington in his text book ([Ref 1](#)) on electrical protection offered the following formula:

$$\text{Discrimination time} = (0.2 + 0.1 t)$$

Where t is the operating time of the down stream device.

(0.2 second constant is based on the use of a 5 cycle breaker)

The introductions of numerical relays further reduced the recommended discrimination times due to the accuracy, consistency and low overshoot of these devices.

The authors of a paper presented in the UK in 1993 on protecting the UK-France Channel Tunnel ([Ref 2.](#)) referred to the high accuracy, low overshoot time and consistency of

electronic protection, coupled with high speed of SF6 breakers used for the project as being the factors they “fully exploited” in determining the minimum grading time margins to be used for the project, which were:

$$\text{Dependent time relay margin} = 0.2t_{(d)} + 0.135 \text{ sec}$$

$$\text{Definite time relay margin} = 0.6t_{(d)} + 0.135 \text{ sec}$$

Where  $t_{(d)}$  is the down stream relay operating time.

---

## Sources of network data

### The Utility Source

Data about the connection to the electricity utility that is the source of the supply to the network under consideration is usually readily available. However there is need to know what to ask for.

Ask a utility for “the fault level” at a particular supply point and some data will generally be forthcoming. But what will that data be? In most instances, I suggest, the response will be to provide a value for *the maximum anticipated 3-phase fault level*. But is this what you need?

The maximum anticipated 3-phase fault level is the maximum fault level value that the utility anticipates may be reached over the period of its planning horizon for the part of its network that is involved. Such a planning horizon may be 5-20 years and may include the effects of major anticipated network developments including substantial augmentations and network reinforcements ... some of which may never become a reality!

So, in this scenario, the answer to the question: “Is this what you need for determining protection settings to apply today?” is, in all probability, “No!”

It may be the value that is need to determine equipment ratings and mechanical/electrical stresses that equipment may need to be designed to withstand over the lifetime of the installation (or at least its planning horizon), but may bear little resemblance to the fault levels that may be experienced, say, between the time of this protection setting review and the next.

I suggest that when a mine electrical engineer requests fault level information from a utility that is appropriate to ask for three sets of fault levels<sup>3</sup> – or equivalent source impedances – these being:

- ❑ Maximum anticipated fault levels (or minimum source impedances) – and request advice of the planning horizon on which these values are based.
- ❑ Normal operating values in the short term – say up to 3-5 years
- ❑ Minimum normal operating fault levels (or maximum source impedances) likely to apply in the short term

---

<sup>3</sup> In some circumstances there may be little difference between these three sets of values (e.g. when the point of supply is remote the utility network and is fed by a long dedicated distribution or transmission line and no significant augmentation is anticipated with the planning horizon period in the vicinity of the point-of-supply).

Values requested should include both 3-phase and single-phase fault levels (or equivalent positive, negative and zero sequence source impedances<sup>4</sup>) to cater for symmetrical and asymmetrical faults.

It is also worth requesting details of the timing and circumstances of any anticipated significant changes from the “short-term” values supplied.

### **“Unknown” network data**

It is not uncommon for some of the impedance details of networks to be missing or unknown – particularly for old networks and especially if adequate records of changes made over the years have not been kept. Sometimes it is also difficult, if not impossible to determine exactly what size and type of cables have been used. At other times, the only data available may be nameplate data. In the case of a transformer, for example, the transformer impedance should be recorded on the nameplate, but the wanted values of the R & X components of the impedance almost certainly will not be.

In these circumstances the judicious exercise of some engineering judgement is called for. It may be necessary to make assumptions about the equipment, use “typical” impedance values or, in more extreme cases, carry out on-site tests to confirm actual data.

A number of text books do quote “typical” network impedance data, but the problem is that this data may include a very wide range of values, and the information may also be very much out-of-date (although, in the case of old installations, it may precisely be the out-of-date information that you need).

A very useful and authoritative guide to estimating impedance values – or relative resistive and reactive components of known impedances is AS3851-1991 “The calculation of short-circuit currents in three-phase a.c. systems” ([Ref 3](#)). More than just an ordinary standard is a useful reference source, and fully worked hand calculations make a worthwhile document to be included in the technical library of every mine.

To quote the preface to AS3851 *“The editorial presentation of this Standard does not follow IEC documents but adopts a concise and systematic approach which should be more readily understood by non-specialist electrical engineers and students of electrical engineering”* and further on *“The reader is provided with data to be assumed in the absence of known data. This is particularly useful in for calculations requiring zero-sequence data.”*

---

<sup>4</sup> It is also worth noting that actual impedance values may be the “safest” to request/work with, mainly because there is no universally accepted standard, that I am aware of, of how fault level values should be determined in the case of asymmetrical faults (e.g. phase-ground faults)!

# Protection philosophies & protection coordination under contingency conditions

## Basic purpose

It is generally well understood that a protection systems and its settings should ensure that selectivity is achieved when faults consistent with maximum fault levels occur. Typical text and reference books dealing with protection coordination concentrate on this issue, but too often they address this exclusively, as if it were all that protection coordination is about. But is not!

Satisfactory operation of protection systems must also be achieved at minimum fault and under contingency operating conditions.

An organisation needs to have a protection philosophy that clearly states the conditions to be met for the protection systems and settings to be judged acceptable. In particular it will define the “safety factors” to be met and contingency, or minimum, fault level conditions that also need to be assessed.

As well as providing an internal working guide, it would also provide a substantial part of a performance specification for outsourced services for protection design or setting reviews.

## Typical Content of a Protection Philosophy

The contents of a Protection Philosophy will typically includes such things as:

- ❑ Maximum fault clearance times under “normal” and “contingency” conditions.
- ❑ Acceptable discrimination times between different types of protection device/switch combinations, e.g. numerical relay/circuit breaker and numerical relay/circuit breaker, electro-mechanical relay/circuit breaker and fuse, fuse and fuse, etc.
- ❑ Basis of fault current calculations for assessing maximum and minimum fault current levels.
- ❑ Contingency operating conditions of the network to be taken into account when assessing performance under minimum fault level conditions
- ❑ Minimum operating factors<sup>5</sup> for different circumstances, e.g. for faults at the extremities of the normal “zone of protection” for the device, or at the extremities of its backup zone.
- ❑ Circumstances in which backup protection backup may not be mandatory: eg. if fuses are to be considered to be inherently reliable
- ❑ Margins to be allowed above “normal” maximum load for current settings; allowances for motor starting, cold-load pickup, transformer inrush, capacitor inrush, etc.

---

<sup>5</sup> “Operating Factor” can be defined as the ratio of the minimum fault current to which a device needs to respond, to the minimum current that will actually cause the protection device to operate. For example, an operating factor of 2.0 implies that the minimum fault current a protection device needs to respond to is equivalent to twice it pickup current

Local circumstances may dictate variations to the general protection philosophy and some industries will have especial requirements to be addressed. In the mining industry, for example, it is expected to be necessary to clearly differentiate requirements to apply to parts of the network that are, or are not, subject to ground fault current limitation.

The evaluation of settings under contingency operating conditions is greatly facilitated by use of protection coordination software that, rather than just being a protection curve plotting utility, actually models protection devices superimposed onto - and responsive to the operating state of - a network model, such as is the case with DataShare's *RELCORD/32 for Windows* Integrated Protection Coordination and Fault Calculation software package. For more information go to: [www.datashare.com.au](http://www.datashare.com.au).

---

## Protection records maintenance

Maintenance of protection records has always been an issue. Particularly if the intent is to have a full history of settings, setting tests and settings reviews, etc. together with full protection device history – repairs, maintenance & updates, etc.

However, even these relatively modest tasks have become much more involved in recent years. Not so long back it was possible to look at a relay on a panel and “know” - based on recognition of the make and model of the device - the function that the device performs. Now, in the era of numerical and “universal” relays, such certain judgements are longer possible.

With relay functionality and characteristics being based on software configuration by the user a whole new level of complexity has become involved. Where the settings of a device may have been as few as two and the full functionality of a device could be described in a manual of less than 50 pages, some protection devices now have literally hundreds of configurable settings and manuals run to 500+ pages!

To make a judgement about what the role of a particular device may involve recourse to past records of the device, or to be fully confident, it even require direct communication with the relay to interrogate its existing configuration and settings.

A further complication is that the management of these settings is, in many cases, only made possible by the use of software configuration tools provided by the device vendor. However, because this software is proprietary and only “talks” to its devices (often even only a limited range of their own devices!) it tends to cause fragmentation of information – even if the protection device vendor’s wishes are fulfilled and their protection devices are standardised on throughout the network. The only hopeful sign on the horizon is the new international substation communication standard IEC 6850 that offers vendor independent access to device settings data.

In response to enquiries from the electricity and mining industries has recently developed a customised electrical protection database known as *ProtectionDb*.

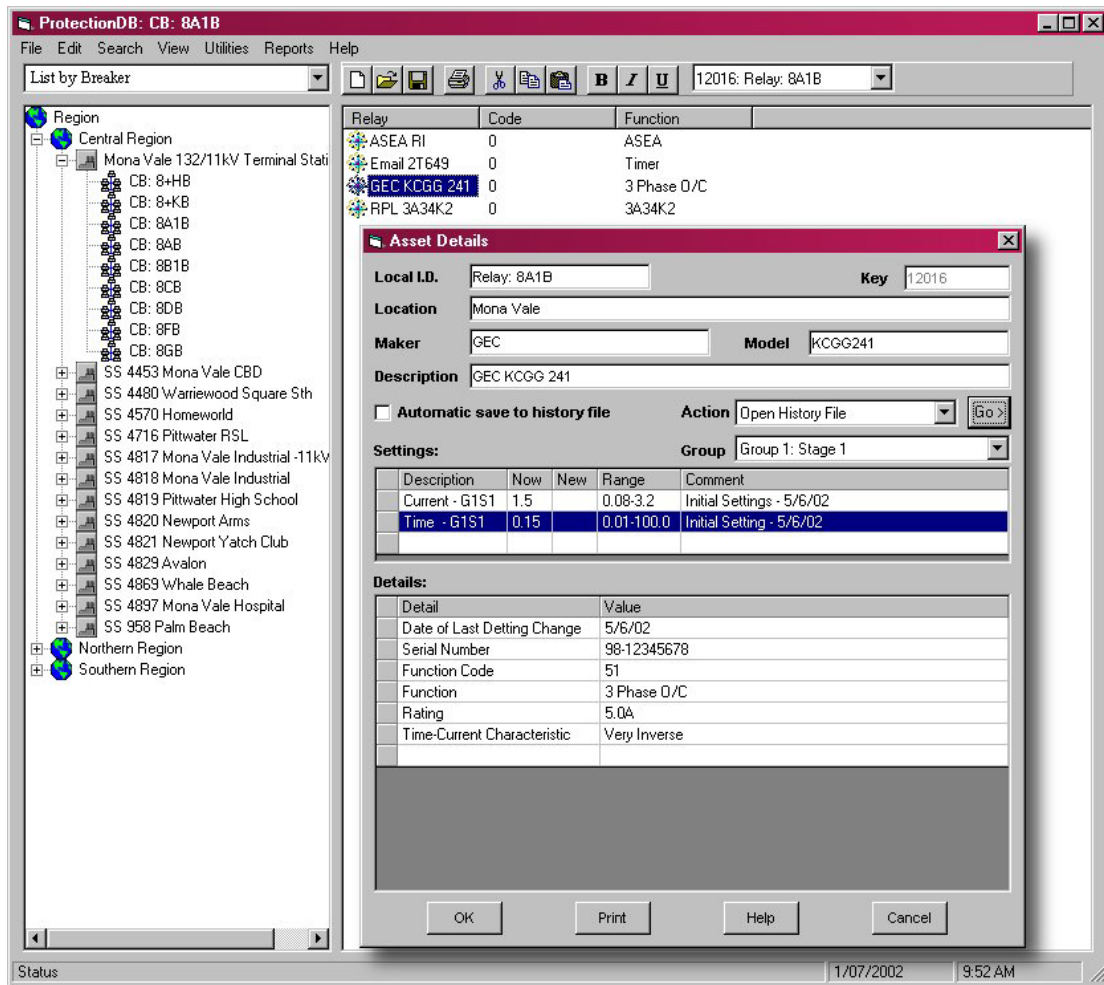

**Figure 4:** Interface of the User Module of DataShare's *ProtectionDb* protection database  
 For more information on ProtectionDb go to: [www.datashare.com.au](http://www.datashare.com.au).

## References

1. Warrington, A.R. Van Cor: **Protective Relays. Their Theory and Practice** – John Wiley & Sons, Vol. 1 Second Edition 1976, p. 6
2. Finn J.S. & Hindle P.J: **Protecting the Channel Tunnel** 5th International Developments in Power System Protection (DPSP '93), University of York, UK, 30 March – 1 April 1993. (IEE Conference Publication No. 368, p 107-110).
3. AS 3851-1991 **The calculation of short-circuit currents in three-phase a.c. systems**, Standards Australia, 1991.